



TechNotes

Editor - Roland Asp, CET

#500

11/22/2022

This edition of Technotes was written by Jeff Dunkel, P.E., Fire Protection Engineer for the NFSA.

Best of NFPA 20 – Expert of the Day

EOD questions are one of NFSA's most used member benefits and are answered by Codes, Standards, and Public Fire Protection Staff members. If you have a question for the NFSA EOD submit your question online through the "My EOD" portal. It should be noted that the following are the opinions of the NFSA Engineering, Codes, and Standards staff, generated as members of the relevant NFPA and ICC technical committees and through our general experience in writing and interpreting codes and standards. They have not been processed as formal interpretations in accordance with the NFPA Regulations Governing Committee Projects or ICC Council Policy #11 and should therefore not be considered, nor relied upon, as the official positions of the NFSA, NFPA, ICC, or its Committees. Unless otherwise noted the most recently published edition of the standard referenced was used.

This TechNotes article is a continuation of a series intended to cover common fire pump questions that are submitted to the Expert of the Day. The first installment in the series is an article in the November/December issue of the National Fire Sprinkler Magazine, which covers four specific questions and the response provided by the NFSA. For this article, in lieu of choosing specific questions we will pick common topics and discuss in detail the NFPA 20 (2022 edition) requirements for that topic. The most common topics addressed by the EOD program are fire pump arrangement, rooms and pump houses, and test headers. General fire pump arrangement was discussed in the March/April edition of the NFSM Article ([Click Here for Article](#)) so that topic will not be repeated in this article. Since most buildings provided with sprinkler systems do not require fire pumps, NFPA 20 can often be an intimidating and confusing standard to understand. The goal of this series is to provide context with the NFPA 20 requirements and reduce confusion for some of the more complicated or uncommon topics in fire pump design.

Pump Rooms

When designing and coordinating sprinkler systems for new construction, one of the most common and difficult issues that arise is getting adequate space for fire sprinkler risers and valves. Since space generally equals money, owners and architects often do not provide adequate space for sprinkler systems. If finding space for sprinkler valves is difficult, imagine notifying an architect their building must have a fire pump when they originally did not plan on having one. While warehouses and high-rise buildings commonly have pumps and space may be provided, there are times other

occupancies, such as buildings in rural areas where water supplies may not be adequate, where a pump would need to be provided. For this reason, coordinating and allocating space and adequate construction for a pump room or house must be provided as early as possible in the project timeline.

Fire Pumps are a critical part of the fire suppression system and protection of the pump and related equipment is paramount. A dedicated pump room must be provided with adequate heat, protection from physical damage, and protection from fire plus enough space for maintenance. A fire pump room can be and often is located within the building it serves; however remote fire pump houses are an option. Outdoor fire pumps are permitted but are far less common and will not be discussed here. Section 4.14 of the 2022 edition of NFPA 20 provides guidance on equipment protection including the requirements for the rooms or remote pump houses.

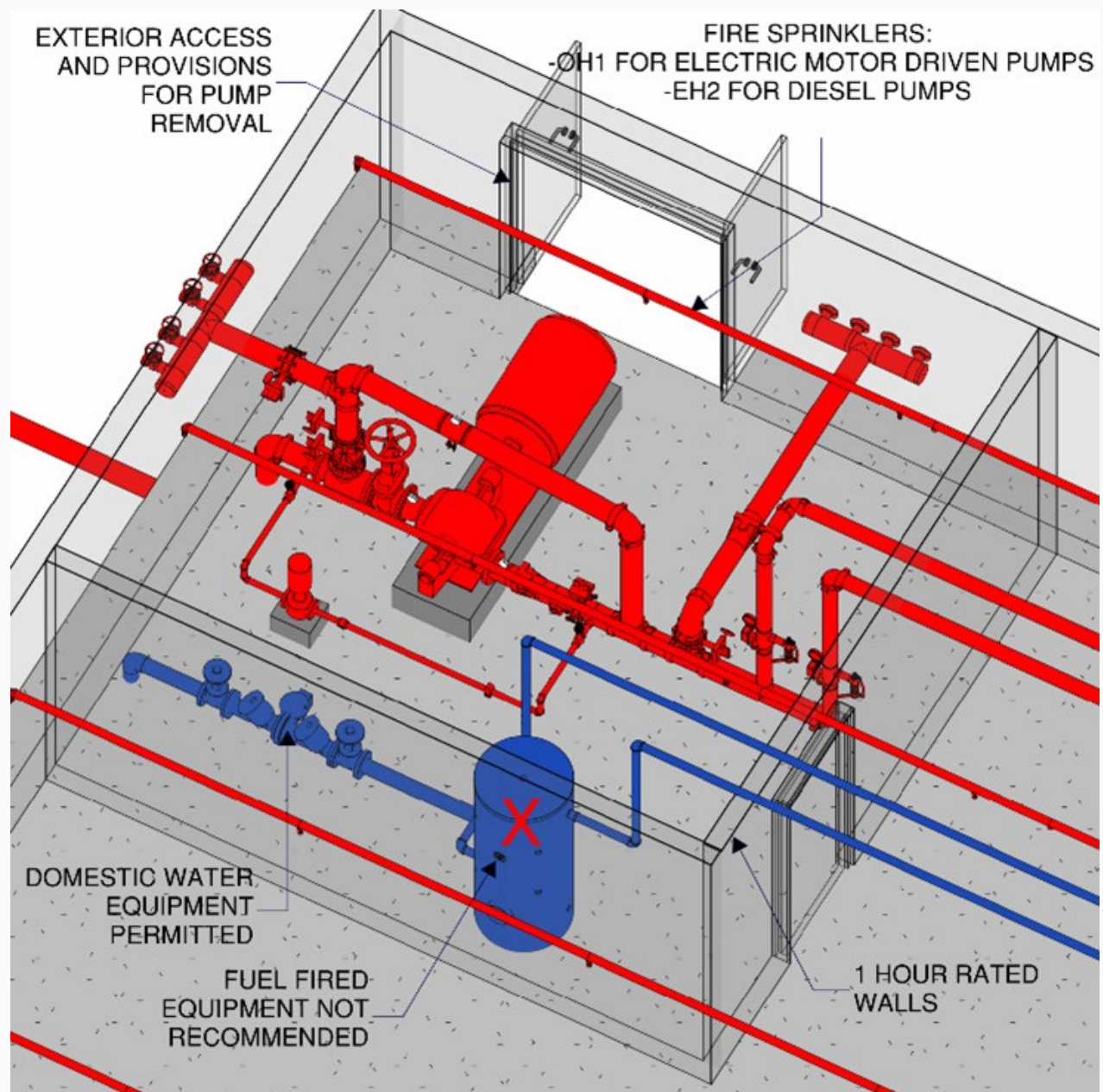



Fire Pump Access

It is important for first responders to have access to the fire pump in the event of a fire, for this reason NFPA 20 Section 4.14.2.1 requires the location of the pump room to be coordinated with the fire department. If a fire pump cannot be located on an exterior wall, a fire-rated path must be provided for access. This ensures that the responding fire department can safely access the fire pump when needed. The one exception to this is for pumps that serve local systems within the building, for example, pumps that serve a water mist system that protect only a portion of the building, in this case the path to the pump simply must not pass through the protected area.

While NFPA 20 does not provide specific criteria for sizing a pump room, the pump room must allow adequate space for installation and maintenance. One aspect that is often missed is provisions for pump removal. It is not uncommon to have a pump skid installed before the room walls are built. This method often causes issues when the pump or components need to be removed or replaced. In the case of a vertical turbine pumps, roof hatches are often needed to install or remove the driver and impeller properly. Future maintenance must be considered and accommodated when designing a fire pump room.

Fire Pump Protection

Protecting a fire pump from fire is essential for obvious reasons. Sprinklers are not always required in pump rooms; however, the separation requirements are dependent on the protection provided. Except for local application pumps, pumps located in high-rise buildings must be in a dedicated room with 2 hour rated walls. For non-high-rise buildings separation requirements are provided by Table 4.14.1.1.2. Generally, if a fire pump is located in a sprinklered building, that sprinkler system is required to extend throughout the building including the pump room. For this reason, the majority of pump rooms in a non-high-rise building require a 1-hour fire-rated wall. For remote pump houses, the criteria is different. In cases where the pump house or a building near the pump house is not protected with sprinklers, a physical separation of 50 feet or the pump house shall have 2 hour rated walls. Even when both the pump house and the exposed building are protected, a 50 foot separation is required, or the pump house must have 1-hour rated walls.

Due to the fuel, diesel pump rooms must be protected by an automatic sprinkler system in compliance with NFPA 13 designed for an extra hazard group 2 occupancy. A sprinkler system is not directly

required for a pump room with an electric motor-driven pump; however, as stated above when located in a sprinklered building that sprinkler system must extend to the pump room. When sprinklers are provided for electric pumps, the system must be designed as an ordinary hazard group 1 occupancy.

Ideally the fire pump room would be dedicated for that purpose, but NFPA 20 does allow for equipment related to domestic water distribution. While equipment for domestic water is permitted, protection from physical damage is important. For this reason, equipment that could damage a pump in the event of a failure should not be in the pump room. This includes fuel-fired water heaters.

Test Headers

Once installation is complete, all fire pumps must be flow tested for a final acceptance test to demonstrate that as installed the pump can achieve the pressures and flows dictated on the manufacturer's certified curve. This initial field acceptance test will be used as a baseline for all future annual fire pump flow tests. This test must verify three points on the flow curve, the pressure at churn or zero flow, the pressure at the rated flow, and the pressure at 150 percent of the rated flow.



Test Header Sizing

The test header provides a convenient means to measure the fire pumps performance. By diverting the pump flow through the test header hose valves to nozzles and calibrated pitot tubes located at a safe location, the flow through the test header can be measured. The number of hose valves open will dictate how much water is flowing. The net pump pressure is measured during the test. This is obtained by subtracting the suction pressure from the discharge pressure of the fire pump. The minimum test header pipe size as well as the number and size of the hose valves required on the test header are provided in Table 4.28. The test header pipe diameter is required to be increased by one pipe size when the pipe length exceeds 15 feet. The 2022 edition of NFPA 20 also added a requirement that the test header pipe needs to be increased by one size when there are more than four fittings that change the direction of the flow. The test header pipe size can also be hydraulically calculated which is a little less straight forward than simply upsizing a pipe. For this reason, we will walk through an example.

Test Header – Hydraulic Calculation Method

In order hydraulically properly calculate the test header pipe size, we must show that the pump discharge pressure is greater than the sum of the pitot pressure needed at the end of the nozzle, the friction loss through hose during the test, the loss or gain of pressure due to elevation, and the friction loss through the test header pipe. This is described in the equation below:

$$P_D > P_P + P_{FH} + P_E + P_{FP}$$

Where:

- P_D = Discharge pressure from pump
- P_P = Pitot pressure needed at end of nozzle
- P_{FH} = Friction loss through hose during test
- P_E = Loss or gain in elevation due to friction loss
- P_{FP} = Friction loss through test header pipe

Since this calculation needs to be based on the worst-case friction loss, we will use the maximum flow from the fire pump or 150% of the rated flow. This also means the discharge pressure of the pump will be the pump's rated pressure at 150% of the rated flow.

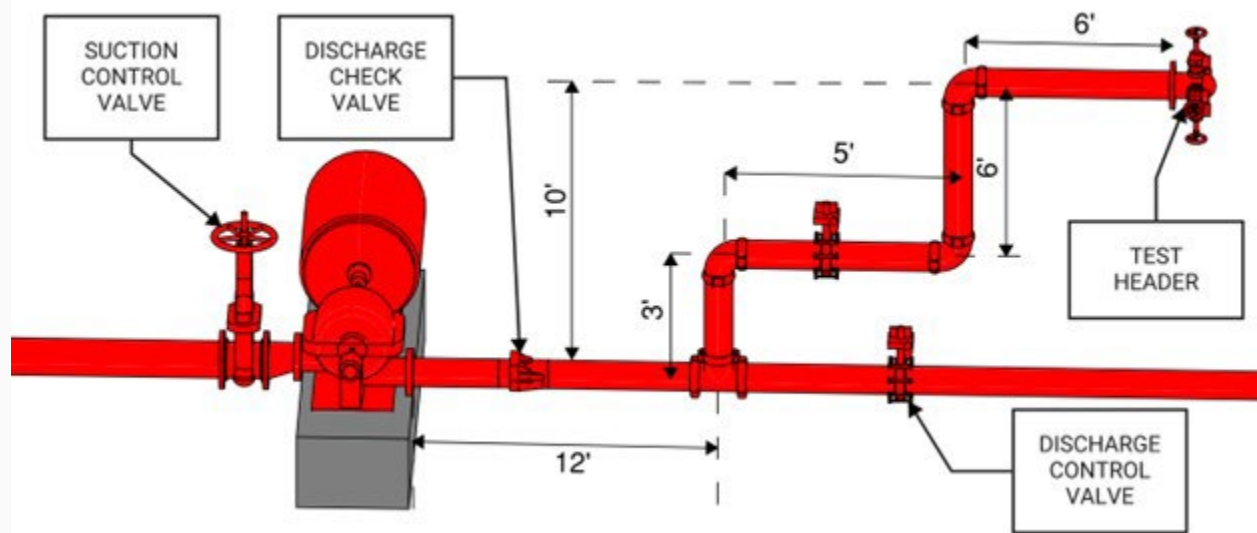

Test Header Calculation Example:

- **Rated Pump Flow:** 1000 gpm
- **Maximum Flow:** 1500 gpm
- **Suction Pressure:** 30 psi at 1500 gpm
- **Net Pressure of Pump at maximum flow:** 58 psi at 1500 gpm

Per Table 4.28 the minimum pipe size for this flow is 6 in. unless we exceed 15 feet in length or there are more than four fittings which change the direction of flow after the initial connection to the discharge pipe. In lieu of upsizing the pipe, we will calculate to show that the 6-inch pipe is acceptable.

Our pump arrangement consists of the following pipes and fittings between the pump discharge and the test header:

- 20 ft. of 6 in. Schedule 40 steel pipe from discharge pipe to test header
- 12 ft. of 6 in. schedule 40 steel pipe from pump discharge to test header line tee
- Fittings
 - 3 elbows (90-degree standard turn)
 - 1 tee
 - check valve
 - OS&Y control valve
- Height of the pitot gauge is 10 ft. above the pump discharge

The discharge pressure (P_D) determined by adding the suction pressure (P_S) to the net discharge pressure (P_N):

$$P_D = P_S + P_N = 30 + 58 = 88 \text{ psi}$$

Since Table 4.28 requires a minimum of 4 hose valves on the test header we must determine how much flow is required through each hose line. We do this by dividing the maximum flow by 4, which means we require 375 gpm per hose line. We will also assume that the end of the hoses will terminate into a 1 3/4 inch nozzle with a coefficient of discharge of 0.97 (straight nozzle).

With this information we can calculate the required pressure measured by the pitot gauge. To do this the formula used to calculate the flow from the pitot based on the pressure reading can be solved for pressure.

$$Q = 29.83cd^2 \sqrt{P_P} \text{ or } P_p = \frac{Q_H^2}{889.8c^2d^4}$$

Using the flow from a single flow of 375 gpm, the assumed 1 ¼ inch nozzle, and the coefficient of discharge of .97 the pitot pressure is calculated as follows:

$$P_p = \frac{(375)^2}{(889.8)(0.97)^2(1.75)^4} = 18 \text{ psi}$$

In order to calculate the friction loss through the hose we must assume a hose type, for this we will assume the hose used for this test will be a 100 ft. of rubber lined hose with a friction loss coefficient of 2. The equation for friction loss through a hose is provided below:

$$P_{FH} = cq^2l$$

Where:

- c = Hose line friction loss coefficient
- q = total flow divided by 100 (Q/100)
- l = total length of hose line divided by 100 (L/100)

Therefore,

$$P_{FH} = 2(3.75)^2(1) = 28 \text{ psi}$$

The friction loss through the supply line leading to test header is done using the Hazen-Williams formula:

$$P_{FP} = \frac{4.52LQ^{1.85}}{C^{1.85}d^{4.87}}$$

Where:

- L = Total length of pipe including equivalent lengths of fittings (32 ft. + 107 ft. = 139 ft.)
- Q = Maximum flow from pump discharge (1500 gpm)
- C = C factor of pipe (Used C factor for steel pipe on a dry pipe system since a portion of this line will be dry = 100)
- d = Internal diameter of pipe (6-inch sch 40 steel pipe = 6.065 in)

Therefore,

$$P_{FP} = \frac{4.52(139\text{ ft})(1500)^{1.85}}{(100)^{1.85}(6.065)^{4.87}} = 14.5\text{ psi}$$

The final variable we must calculate is the pressure loss or gain due to elevation. Since the pitot gauge will be 10 ft. above the pump discharge, we are gaining pressure from the pitot gauge to the pump discharge. This pressure is calculated by multiplying the elevation change by .433 psi/ft. shown below:

$$P_E = .433 \frac{\text{psi}}{\text{ft}} \times 10\text{ ft} = 4\text{ psi}$$

With all of the variables we can now compare the values downstream of the discharge to the discharge pressure:

$$P_D > P_P + P_{FH} + P_{FP} + P_E$$

$$P_D = 88 \text{ psi}$$

$$P_P + P_{FH} + P_{FP} + P_E = 18 \text{ psi} + 28 \text{ psi} + 4 \text{ psi} + 14.5 \text{ psi} = 60 \text{ psi}$$

$$88 \text{ psi} > 64.5 \text{ psi}$$

As we have demonstrated using a 6-inch schedule 40 steel pipe in this case is acceptable. It is important to note that the same hose types, lengths, and nozzle size should be noted and used for all future annual tests.

Immediate Resources and a FREE CEU!

Join us for [Tech Tuesday: Best of NFSA's Expert of the Day: NFPA 20 – Fire Pumps on December 20th](#). For this session, the most frequently asked and top questions fire pump requirements in NFPA 20 are being presented and discussed. This event is free to all members and qualifies as 1 CEU by most accrediting agencies.

[Register for Tech Tuesday Here](#)



Learning and Development

It's Time to Start Thinking About 2023

Start off 2023 with:



Participate in NFSA's Layout Technician Pathway!

Our first offering of Layout Technician: Application is happening January 24-26, 2023.

Registration Deadline: December 24, 2022

[Learn More Here](#)

The National Fire Sprinkler Association is proud to present our NEW 2019-2020 Edition EOD Handbook

The EOD Handbook is now a three-volume set of over 1,500 pages covering hundreds of topics that are relevant to automatic fire sprinkler systems, standpipes, water supplies, inspection, testing and maintenance, codes, and standards.

Order the latest volume, the 2019-2020 Edition, as a single book or order the three-volume set!



National Fire Sprinkler Association

514 Progress Dr, Ste A,
Linthicum Heights, MD 21090
1-800-683-NFSA (6372)



[Manage my Preferences](#)

[Unsubscribe](#)